

FD 138-18 DS

Double Convolution Air Actuator

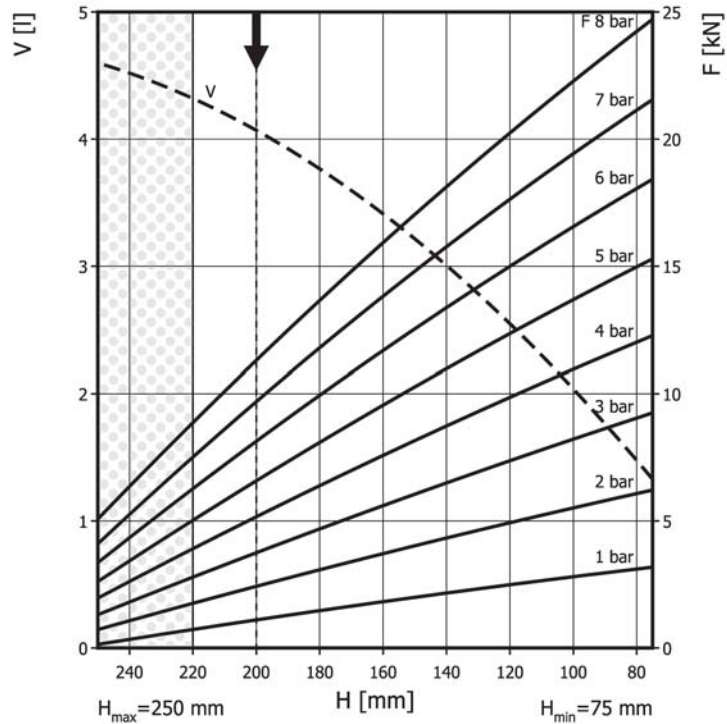

Use in dotted range >220 mm only after consultation with ContiTech

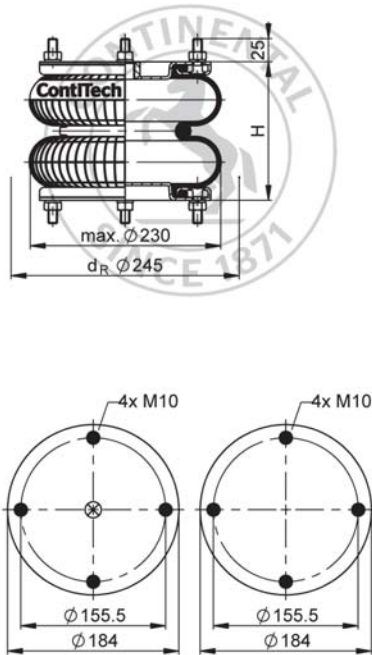

Recommended height for vibration isolation: 200 mm

Purchase order data

Type	Order No.
Rubber bellows only	66501
with dismountable plates, G1/2 air inlet	66505

Additional types on request



Service instructions
M10: max. 25 Nm
G1/2: max. 25 Nm

Technical data

Min. pressure	0 bar
Return force to min height	≤ 300 N
Overall weight	3.5 kg

Vibration isolation - dynamic characteristic values

Design height H: recommended 200mm, minimum 180mm

Pressure p [bar]	3	4	5	6	7	8	Vol. V [l]
Force (Load) [kN]	3.9	5.3	6.7	8.2	9.7	11.3	4.1
Spring rate [N/mm]	76	97	118.5	140	161	181.5	
Natural frequency [Hz]	2.2	2.2	2.1	2.1	2.1	2.0	

Pneumatic application - static characteristic values

Force F [kN]

Pressure p [bar]	3	4	5	6	7	8	Vol. V [l]
Height H [mm]	220	2.9	4.03	5.16	6.41	7.65	4.3
	200	3.86	5.27	6.68	8.21	9.73	4.1
	150	5.9	8	10.1	12.4	14.7	3.2
	100	8.2	10.9	13.7	16.6	19.4	2