

FD 1710-25 RS Double Convolution Air Actuator

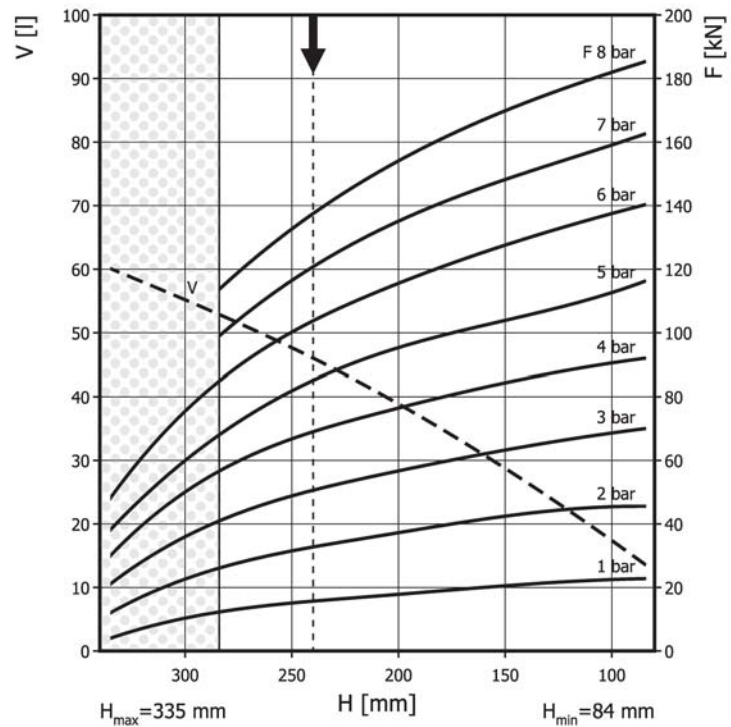

Use in dotted range >284 mm only after consultation with ContiTech

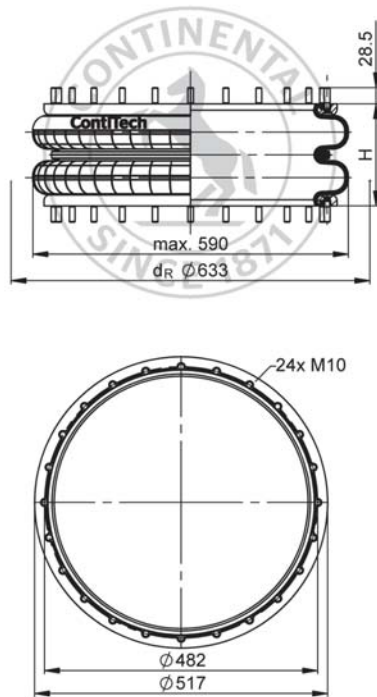

Recommended height for vibration isolation: 240 mm

Purchase order data

Type	Order No.
Rubber bellows only	61783
with bead rings, 45 mm bolts, nuts and washers	61905

Additional types on request

Technical data

Min. pressure	0 bar
Return force to min height	≤ 440 N
Overall weight	12 kg

Vibration isolation - dynamic characteristic values

Design height H: recommended 240mm, minimum 220mm

Pressure p [bar]	3	4	5	6	7	8	Vol. V [l]
Force (Load) [kN]	51.6	69.4	86.6	102.8	121.1	136.6	46
Spring rate [N/mm]	536	682	836	970	1120	1256	
Natural frequency [Hz]	1.6	1.6	1.6	1.5	1.5	1.5	

Pneumatic application - static characteristic values

Force F [kN]

Pressure p [bar]	3	4	5	6	7	8	Vol. V [l]	
Height H [mm]	280	42.1	57.8	69.6	86.4	101	116	52
	240	49.8	68.4	85.4	103	121	138	46
	200	57	76.5	95.4	116	136	154	39
	160	61.9	82.6	102	125	146	167	31
	120	66.3	88.1	109	134	155	178	22



Service instructions
M10: max. 40 Nm