

FD 40-10 CI

Double Convolution Air Actuator

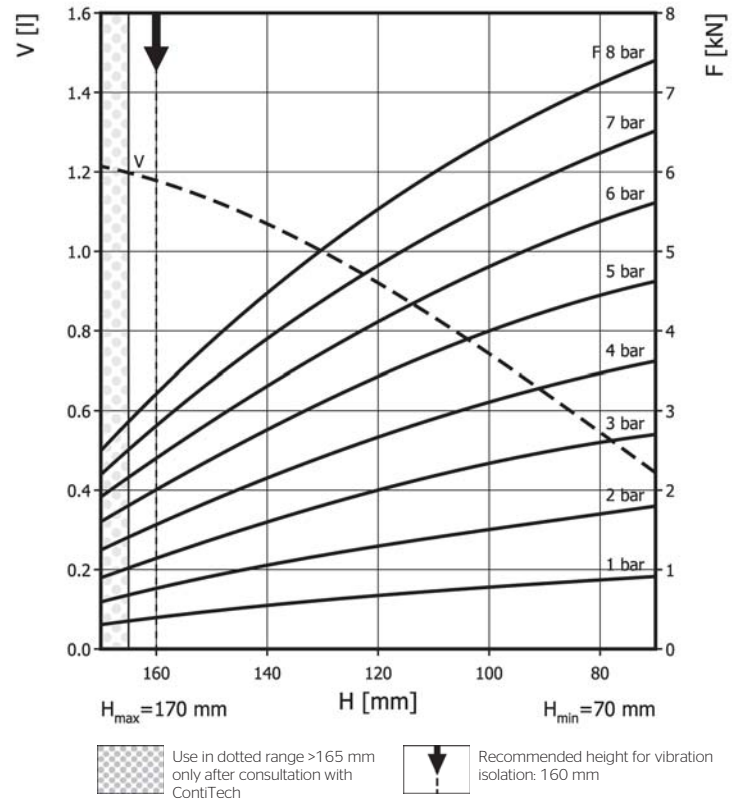
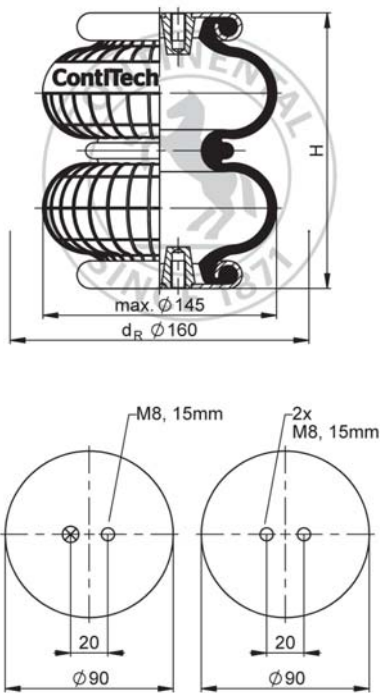

Purchase order data

Type	Order No.
Rubber bellows only	72586
with crimped plates, G1/8 air inlet 10 mm excentrical	2682001000
with stainless steel crimped plates, G1/8 air inlet 0 mm excentrical	61755

Additional types on request



Service instructions
M8: max. 25 Nm
G1/8: max. 25 Nm

Technical data

Min. pressure	0 bar
Return force to min height	≤ 200 N
Overall weight	1.3 kg

Vibration isolation - dynamic characteristic values

Design height H: recommended 160mm, minimum 150mm

Pressure p [bar]	3	4	5	6	7	8	Vol. V [l]
Force (Load) [kN]	1.1	1.5	2	2.4	2.8	3.2	1.2
Spring rate [N/mm]	34	45	58	70	82.5	95	
Natural frequency [Hz]	2.8	2.8	2.7	2.7	2.7	2.7	

Pneumatic application - static characteristic values

Force F [kN]

Pressure p [bar]	3	4	5	6	7	8	Vol. V [l]	
Height H [mm]	160	1.12	1.55	2	2.4	2.8	3.2	1.2
	140	1.6	2.17	2.8	3.3	3.9	4.5	1.1
	120	2	2.65	3.4	4.1	4.8	5.5	0.9
	100	2.3	3.1	4	4.8	5.6	6.4	0.7
	80	2.6	3.5	4.47	5.4	6.26	7.1	0.6