

FD 412-18 DS

Double Convolution Air Actuator

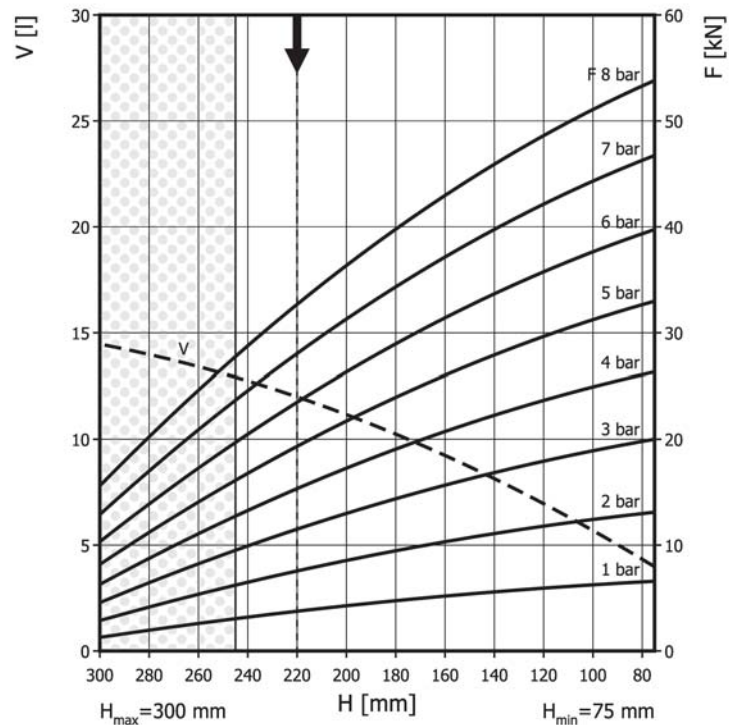

Use in dotted range >245 mm only after consultation with ContiTech

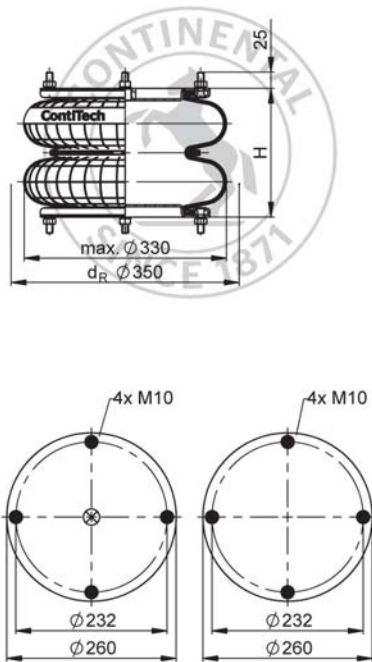

Recommended height for vibration isolation: 220 mm

Purchase order data

Type	Order No.
Rubber bellows only	66318
with dismountable plates, G1/2 air inlet	66334

Additional types on request

Technical data

Min. pressure	0 bar
Return force to min height	≤ 250 N
Overall weight	6.6 kg

Vibration isolation - dynamic characteristic values

Design height H: recommended 220mm, minimum 200mm

Pressure p [bar]	3	4	5	6	7	8	Vol. V [l]
Force (Load) [kN]	12	16.3	20.4	24.5	28.7	32.9	12
Spring rate [N/mm]	155	200	244	286.5	331	374	
Natural frequency [Hz]	1.8	1.8	1.7	1.7	1.7	1.7	

Pneumatic application - static characteristic values

Force F [kN]

Pressure p [bar]	3	4	5	6	7	8	Vol. V [l]	
Height H [mm]	250	9.38	12.5	15.8	19.4	23.2	27.2	13
	200	12.9	17.2	21.6	26.2	31.2	36.1	11
	150	15.9	21.1	26.5	32	37.9	44	8.5
	100	19.1	25.2	31.5	38	44.8	51.6	5.6

 Service instructions
 M10: max. 25 Nm
 G1/2: max. 25 Nm