

FS 1710-12 RS

Single Convolution Air Actuator

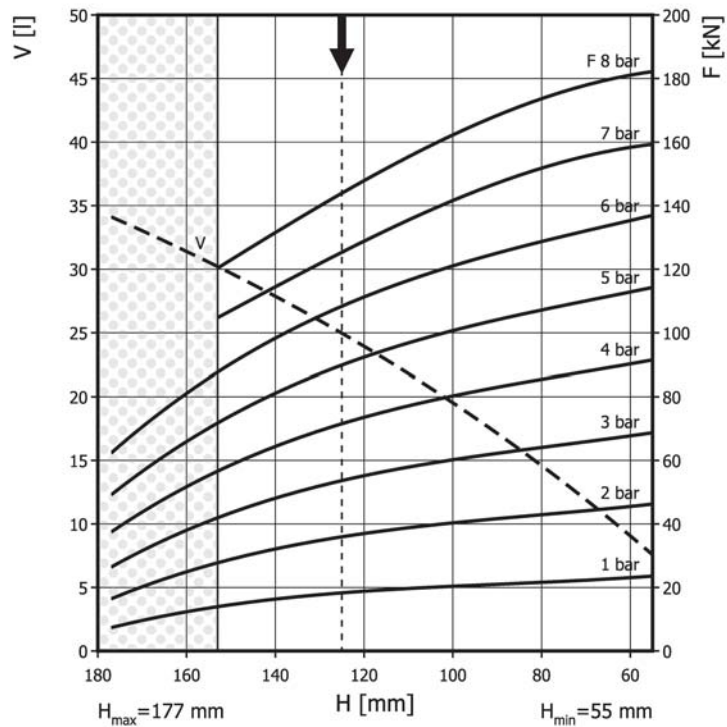

Use in dotted range >153 mm only after consultation with ContiTech

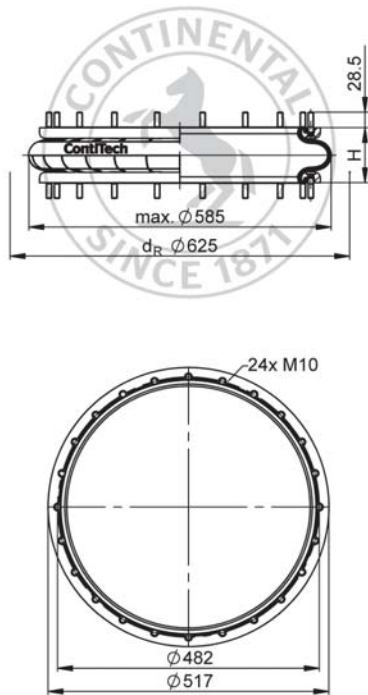

Recommended height for vibration isolation: 125 mm

Purchase order data

Type	Order No.
Rubber bellows only	61782
with bead rings, 45 mm bolts, nuts and washers	61900

Additional types on request

Technical data

Min. pressure	0 bar
Return force to min height	≤ 730 N
Overall weight	8.7 kg

Vibration isolation - dynamic characteristic values

Design height H: recommended 125mm, minimum 110mm

Pressure p [bar]	3	4	5	6	7	8	Vol. V [l]
Force (Load) [kN]	53.6	70.6	87.5	110	126.7	145.7	25
Spring rate [N/mm]	1019	1288	1551	1897	2154	2448	
Natural frequency [Hz]	2.2	2.2	2.1	2.1	2.1	2.1	

Pneumatic application - static characteristic values

Force F [kN]

Pressure p [bar]	3	4	5	6	7	8	Vol. V [l]	
Height H [mm]	140	48.2	64.4	81.2	98	115	132	28
	120	53.8	72.1	90.6	109	128	147	24
	100	60.2	80.2	101	121	142	162	19
	80	65	86.6	109	130	152	174	15
	60	67.8	90.2	113	136	158	181	9.5



Service Instructions
M10: max. 40 Nm