

# LG 2050-8

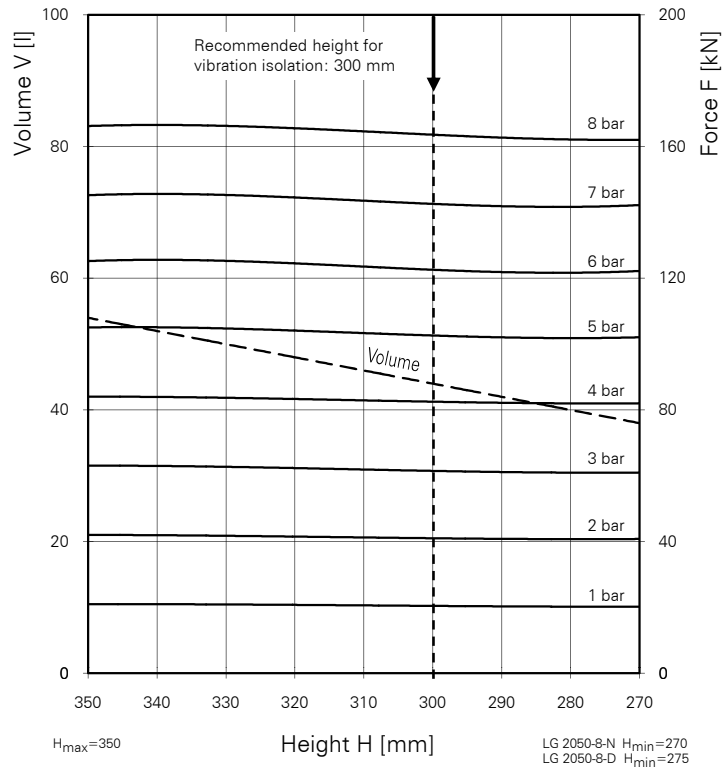
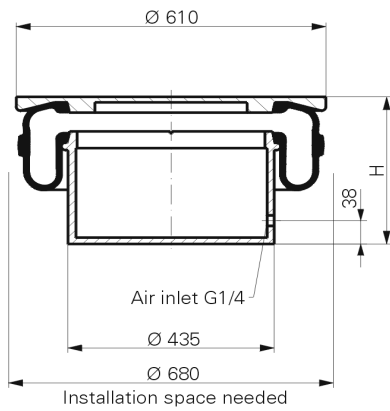

## Purchase order data

Type	Order No.
Type LG 2050-8-N with G 1/4 air inlet	60997
Type LG 2050-8-D with air-based damping, with G 1/4 air inlet	60148

Additional types on request



Service instructions  
G1/4: max. 25 Nm

## Technical data

Min. pressure	0 bar
Return force to min height	≤ 1200 N
Total weight, version N (version D)	112 kg

### Vibration isolation - dynamic characteristic values

Operation height H: 300 mm

Pressure p [bar]	3	4	5	6	7	8	Vol. V [l]
Force (Load) [kN]	62	83	104	124	144	165	44
Spring rate [N/mm]	620	75	85	96	104.5	114.5	
Natural frequency [Hz]	1.6	1.5	1.4	1.4	1.4	1.3	
Stiffness lateral [N/mm]	490	530	560	580	610	650	
Natural lateral [Hz]	1.4	1.3	1.2	1.1	1.1	1.0	

### Pneumatic application - static characteristic

Values Force F [kN]

Pressure p [bar]	3	4	5	6	7	8	Vol. V [l]
Height H [mm]	350	63	84	105	125	145	54
	320	62	83	104	124	144	48
	290	61	82	102	122	142	42