

FD 200-19 CI

Double Convolution Air Actuator

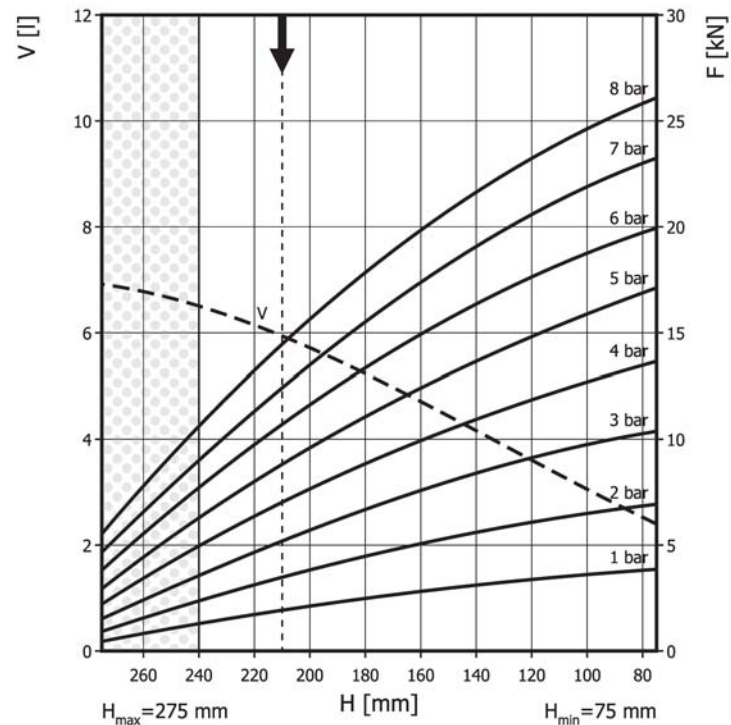

Use in dotted range >240 mm only after consultation with ContiTech

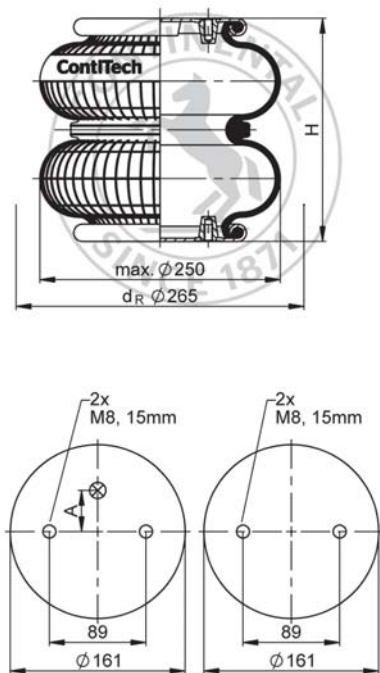

Recommended height for vibration isolation: 210 mm

Purchase order data

Type	Order No.
Rubber bellows only	60508
with crimped plates, G1/4 air inlet (A) 44.5 mm excentrical	60336
with crimped plates, G3/4 air inlet (A) 38.1 mm excentrical	2682045000

Additional types on request



Service instructions
M8: max. 25 Nm
G1/4: max. 25 Nm
G3/4: max. 50 Nm

Technical data

Min. pressure	0 bar
Return force to min height	≤ 200 N
Overall weight	3 kg

Vibration isolation - dynamic characteristic values

Design height H: recommended 210mm, minimum 195mm

Pressure p [bar]	3	4	5	6	7	8	Vol. V [l]
Force (Load) [kN]	5.2	7.1	9	10.7	12.4	14.5	
Spring rate [N/mm]	79.5	103	126.5	150	173.5	197	
Natural frequency [Hz]	2.0	1.9	1.9	1.9	1.9	1.9	

Pneumatic application - static characteristic values

Force F [kN]

Pressure p [bar]	3	4	5	6	7	8	Vol. V [l]	
Height H [mm]	230	4.1	5.6	7.19	8.78	10.1		12
	200	5.66	7.66	9.61	11.6	13.5	15.6	5.7
	170	7.16	9.4	11.7	14.2	16.5	18.9	5
	140	8.4	10.9	13.7	16.4	19	21.5	4.1
	110	9.43	12.4	15.4	18.3	21.3	24.1	3.4
	80	10.3	13.4	16.9	19.7	23	25.8	2.5