

# FD 200-22 CI

# Double Convolution Air Actuator

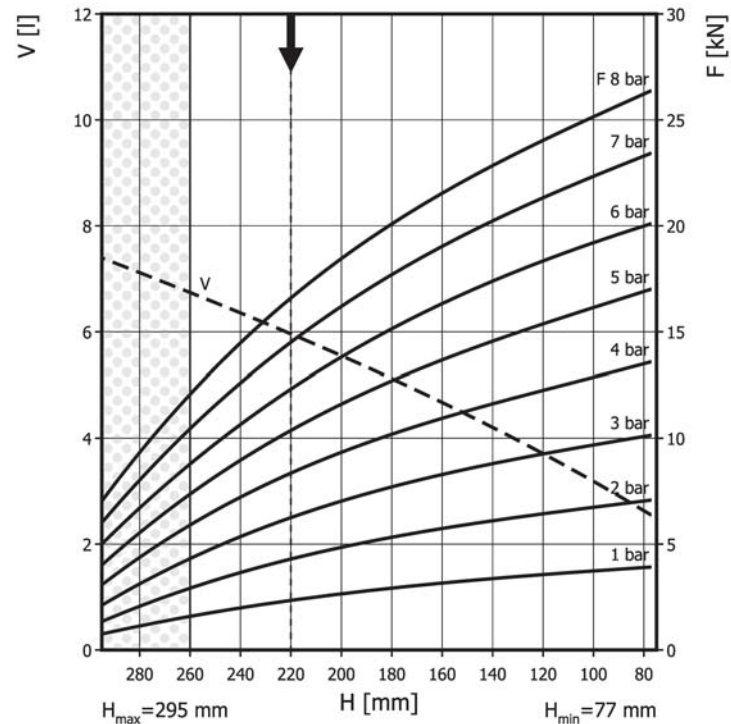
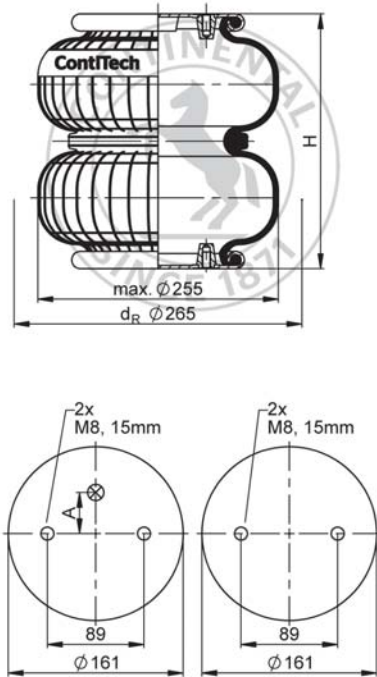

Use in dotted range >260 mm only after consultation with ContiTech

Recommended height for vibration isolation: 220 mm

### Purchase order data

Type	Order No.
Rubber bellows only	71983
with crimped plates, G1/4 air inlet (A) 44.5 mm excentrical	60936
with crimped plates, G1/4 air inlet (A) 44.5 mm excentrical	61363
with crimped plates, G3/4 air inlet (A) 38.1 mm excentrical	60608

Additional types on request



Service instructions  
 M10: max. 25 Nm  
 M8: max. 25 Nm  
 G1/4: max. 25 Nm  
 G3/4: max. 50 Nm

### Technical data

Min. pressure	0 bar
Return force to min height	≤ 200 N
Overall weight	3.2 kg

#### Vibration isolation - dynamic characteristic values

Design height H: recommended 220mm, minimum 205mm

Pressure p [bar]	3	4	5	6	7	8	Vol. V [l]
Force (Load) [kN]	6.1	8.2	10.3	12.5	14.5	16.5	
Spring rate [N/mm]	75	96	111	134	151	173	
Natural frequency [Hz]	1.8	1.7	1.7	1.6	1.6	1.6	

#### Pneumatic application - static characteristic values

Force F [kN]

Pressure p [bar]	3	4	5	6	7	8	Vol. V [l]
Height H [mm]	250	4.9	6.6	8.2	9.66	11.5	
	210	6.7	8.8	11	13.3	15.5	5.8
	170	7.9	10.5	13.1	15.7	18.3	4.9
	130	9.1	12	15	17.8	20.7	4
	90	9.9	13.2	16.6	19.6	22.9	2.9