

# FD 200-25 CI

# Double Convolution Air Actuator

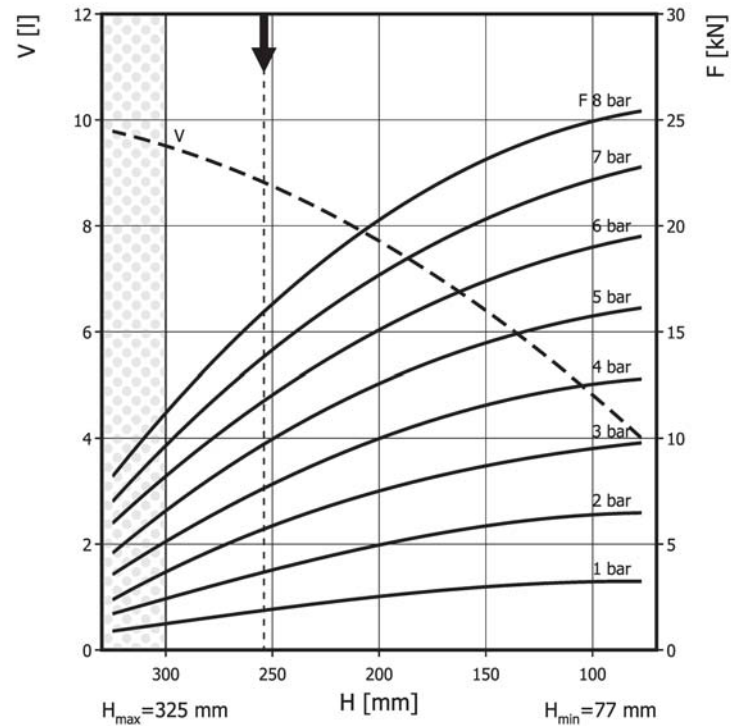
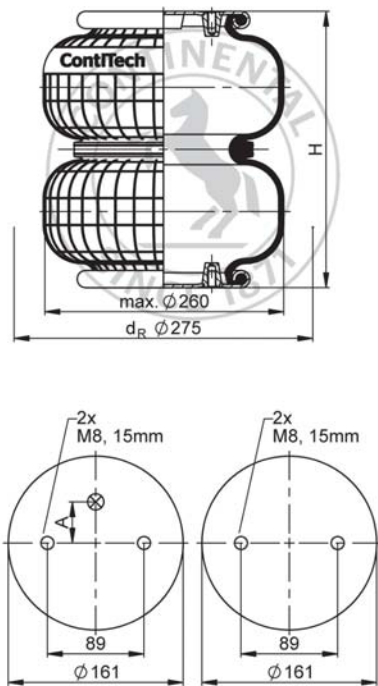

Use in dotted range >300 mm only after consultation with ContiTech

Recommended height for vibration isolation: 254 mm

### Purchase order data

Type	Order No.
Rubber bellows only	60515
with crimped plates, G1/4 air inlet (A) 44.5 mm excentrical	60555
with crimped plates, G3/4 air inlet (A) 38.1 mm excentrical	60382
with stainless steel crimped plates, G3/4 air inlet (A) 38.1 mm excentrical	67781

Additional types on request



Service instructions  
 M8: max. 25 Nm  
 G1/4: max. 25 Nm  
 G3/4: max. 50 Nm

### Technical data

Min. pressure	0 bar
Return force to min height	≤ 250 N
Overall weight	3.5 kg

#### Vibration isolation - dynamic characteristic values

Design height H: recommended 254mm, minimum 230mm

Pressure p [bar]	3	4	5	6	7	8	Vol. V [l]
Force (Load) [kN]	6	8.1	10.2	12.3	14.4	16.5	
Spring rate [N/mm]	73	93	120	139	166	184	
Natural frequency [Hz]	1.8	1.8	1.7	1.7	1.7	1.7	8.8

#### Pneumatic application - static characteristic values

Force F [kN]

Pressure p [bar]	3	4	5	6	7	8	Vol. V [l]	
Height H [mm]	290	4.12	5.64	7.3	9.03	10.5		12.4
	260	5.55	7.34	9.38	11.3	13.4		15.4
	230	6.56	8.83	11.1	13.4	15.8		18.1
	200	7.5	9.92	12.5	15	17.6		20.2
	170	8.28	11	13.8	16.6	19.4		22.2
	140	8.91	11.8	14.8	17.7	20.7		23.6
	110	9.3	12.3	15.6	18.7	21.9		24.6
	77	9.3	12.3	15.6	18.7	21.9	24.6	