

# FD 530-30 CI

# Double Convolution Air Actuator

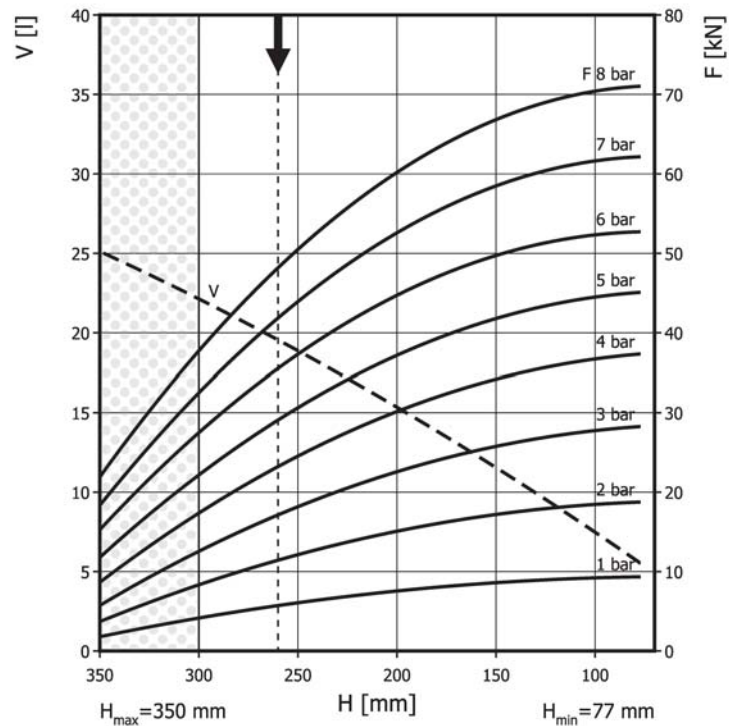
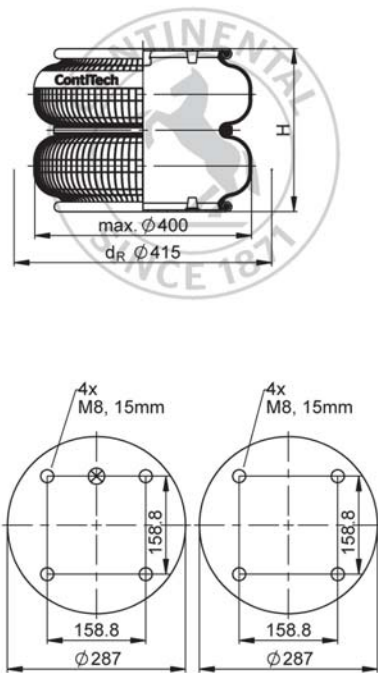

Use in dotted range >300 mm only after consultation with ContiTech

Recommended height for vibration isolation: 260 mm

### Purchase order data

Type	Order No.
Rubber bellows only	60494
with crimped plates, G1/4 air inlet, 79.4 mm excentrical	61364
with crimped plates, G3/4 air inlet, 79.4 mm excentrical	75141
with crimped plates, G1 air inlet, 79.4 mm excentrical	60434
with stainless steel crimped plates, G3/4 air inlet, 79.4 mm excentrical	68331

Additional types on request



Service instructions  
 M8: max. 25 Nm  
 G1/4: max. 25 Nm  
 G1: max. 50 Nm  
 G3/4: max. 50 Nm

### Technical data

Min. pressure	0 bar
Return force to min height	≤ 400 N
Overall weight	7.3 kg

#### Vibration isolation - dynamic characteristic values

Design height H: recommended 260mm, minimum 245mm

Pressure p [bar]	3	4	5	6	7	8	Vol. V [l]
Force (Load) [kN]	17.3	23.4	29.3	35.9	42.3	48.2	20
Spring rate [N/mm]	188	235	287.5	339	385	445	
Natural frequency [Hz]	1.6	1.6	1.6	1.5	1.5	1.5	

#### Pneumatic application - static characteristic values

Force F [kN]

Pressure p [bar]	3	4	5	6	7	8	Vol. V [l]
Height H [mm]	300	13	17.7	22.2	27.7	32.8	38.4
	260	17.3	23.4	29.3	35.9	42.3	48.2
	220	20.9	28	34.8	42	49.3	56.4
	180	23.7	31.9	39	46.9	55.1	63.2
	140	26.1	34.6	42.3	50.2	59.3	67.8
	100	27.9	36.8	44.7	52.4	61.7	70.5
							7.4