

SCHWINGMETALL® Hydromounts

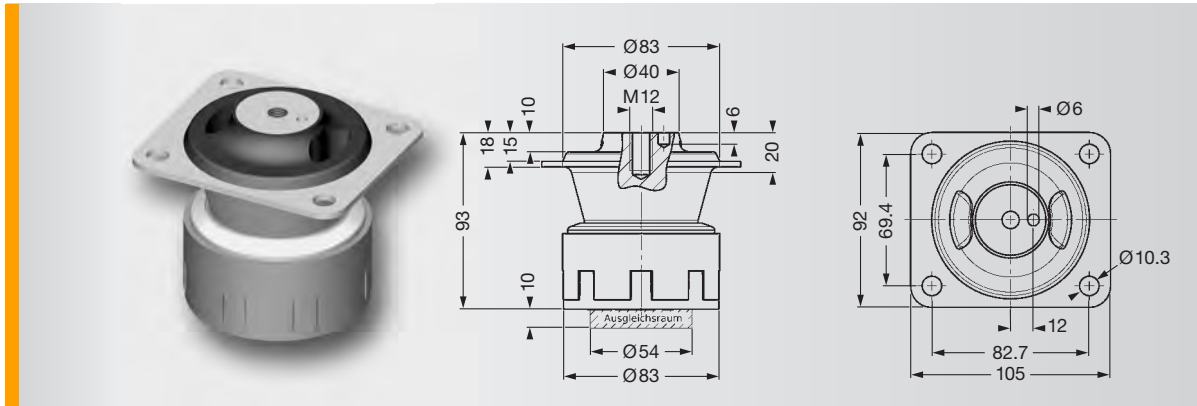

Hydromount K 2000

Hydro-mount	Mould No.	Part No.	Spring Stiffness			Max. Loads			Mass Piece [kg]	Elastomer Hardness [Shore A]
			C_x [N/mm]	C_y [N/mm]	C_z [N/mm]	F_x [N]	F_y [N]	F_z [N]		
K 2000	212745	400006687	1200	1500	390	4500	6000	1800	1.2	55

► Hydromount K 2000: stopper disk in z direction min. Ø 80 mm required

Characteristic Curves Hydromount K 2000

55 Shore A

