

FS 5450-16 RS

Single Convolution Air Actuator

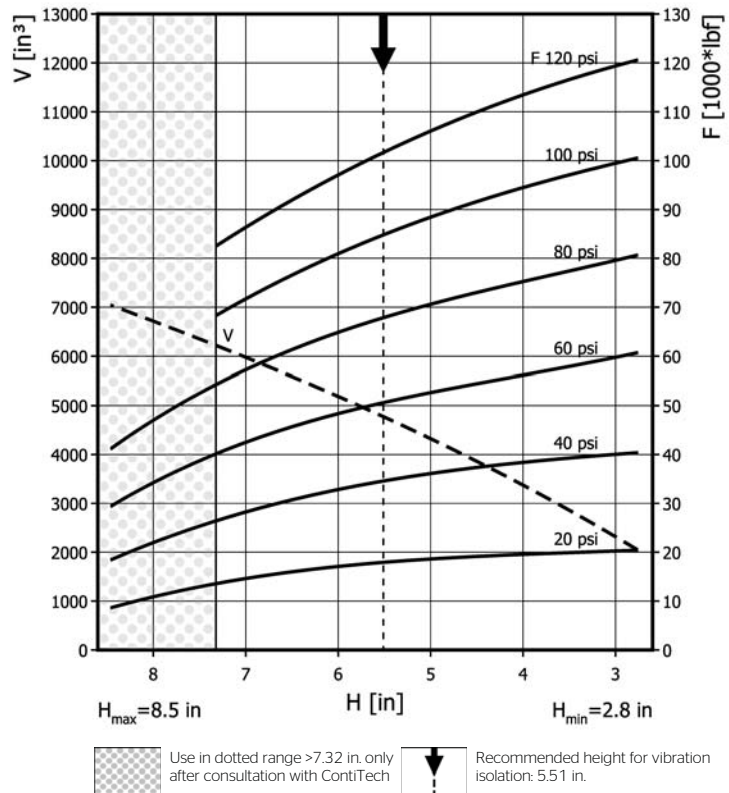
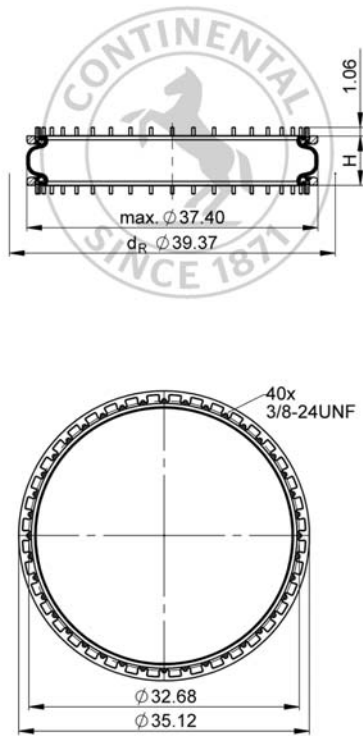

Purchase order data

Type	Order No.
Rubber bellows only	61785
WR SMS48	75385

Additional types on request

Technical data

Min. pressure	0 psi
Return force to min height	≤ 337 lbf
Overall weight	48.5 lb

Vibration isolation - dynamic characteristic values

Design height H: recommended 5.51 inch, minimum 4.72 inch

Pressure p [psi]	40	60	80	100	120	Vol. V [in³]
Force (Load) [lbf]	33400	50500	67600	84800	10200	4720
Spring rate [lbf/in.]	13700	19400	24900	30300	35600	
Natural frequency [Hz]	2.0	2.0	1.9	1.9	1.9	

Pneumatic application - static characteristic values

Force F [lbf]

Pressure p [psi]	40	60	80	100	120	Vol. V [in³]	
Height H [in.]	7.0	27900	42300	57100	71800	86100	6000
	6.5	30500	45100	61000	76400	91700	5600
	6.0	32500	47800	64500	80800	96900	5200
	5.5	34200	50500	67800	84900	10200	4700
	5.0	35900	52600	70400	88300	10600	4300
	4.5	37500	54600	73100	91600	11000	3800
	4.0	38900	56400	75600	94700	11400	3400
	3.5	39300	58100	77600	96900	11600	2900
	3.0	39800	59800	79500	99300	11900	2300



Service instructions
3/8-24 UNF: max. 30 lbf ft