

FD 1710-25 RS ECO Double Convolution Air Actuator

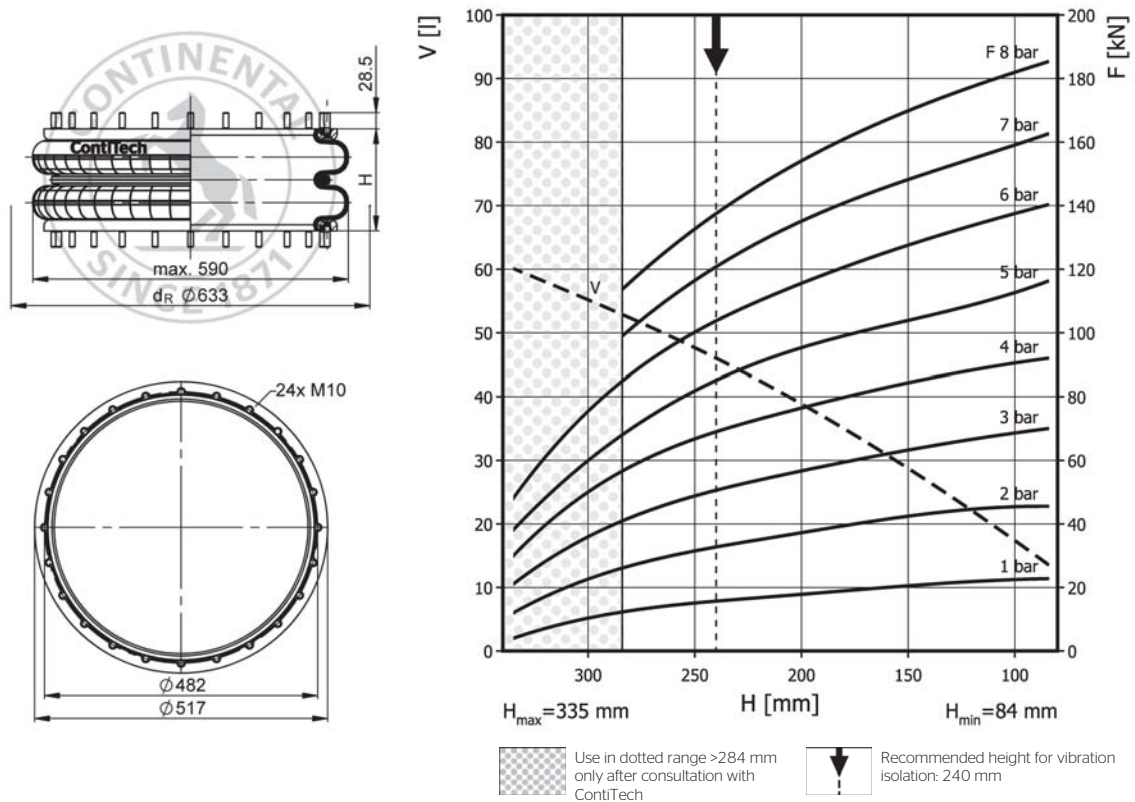

Purchase order data

Type	Order No.
ECO Rubber bellows only	75783
with bead rings, 45 mm bolts, nuts and washers	on request

Additional types on request

 Service instructions
 M10: max. 40 Nm

Technical data

Min. pressure	0 bar
Return force to min height	≤ 440 N
Overall weight	12 kg

Vibration isolation - dynamic characteristic values

Design height H: recommended 240mm, minimum 220mm

Pressure p [bar]	3	4	5	6	7	8	Vol. V [l]
Force (Load) [kN]	51.6	69.4	86.6	102.8	121.1	136.6	46
Spring rate [N/mm]	536	682	836	970	1120	1256	
Natural frequency [Hz]	1.6	1.6	1.6	1.5	1.5	1.5	

Pneumatic application - static characteristic values

Force F [kN]

Pressure p [bar]	3	4	5	6	7	8	Vol. V [l]
Height H [mm]	280	42.1	57.8	69.6	86.4	101	116
	240	49.8	68.4	85.4	103	121	138
	200	57	76.5	95.4	116	136	154
	160	61.9	82.6	102	125	146	167
	120	66.3	88.1	109	134	155	178