

## FD 120-17 CI

## Double Convolution Air Actuator

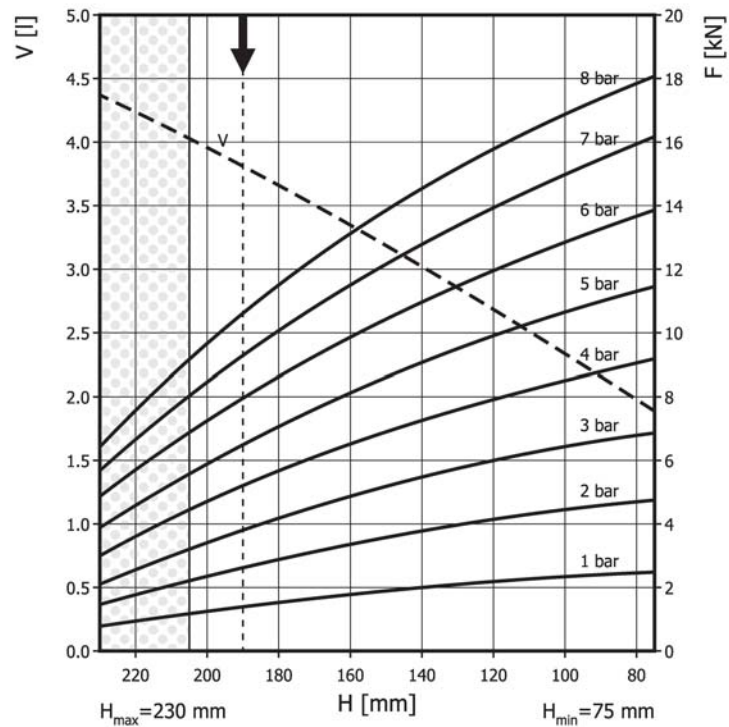

Use in dotted range &gt;205 mm only after consultation with ContiTech

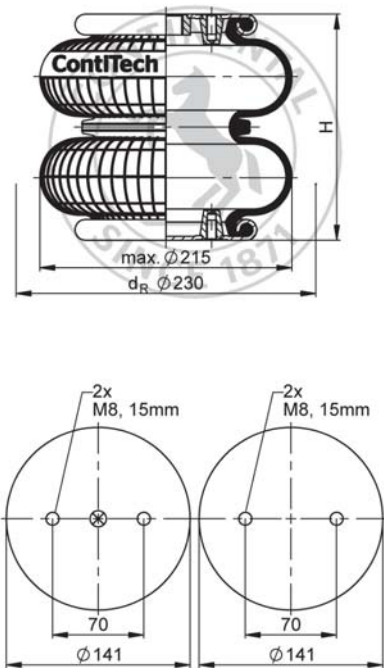

Recommended height for vibration isolation: 190 mm

## Purchase order data

Type	Order No.
Rubber bellows only	60221
with stainless steel crimped plates, G3/4 air inlet 0 mm excentrical	67460

Additional types on request

 Service instructions  
 M8: max. 25 Nm  
 G1/4: max. 25 Nm  
 G3/4: max. 50 Nm

## Technical data

Min. pressure	0 bar
Return force to min height	≤ 200 N
Overall weight	2.3 kg

## Vibration isolation - dynamic characteristic values

Design height H: recommended 190mm, minimum 175mm

Pressure p [bar]	3	4	5	6	7	8	Vol. V [l]
Force (Load) [kN]	3.8	5.2	6.5	8	9.3	10.6	3.8
Spring rate [N/mm]	60	83	106	129	152	175	
Natural frequency [Hz]	2.1	2.0	2.0	2.0	2.0	2.0	

## Pneumatic application - static characteristic values

Force F [kN]

Pressure p [bar]	3	4	5	6	7	8	Vol. V [l]
Height H [mm]	200	3.4	4.75	5.9	7.25	8.5	4
	180	4.18	5.65	7.05	8.6	10.1	3.6
	160	4.9	6.5	8.13	9.85	11.5	3.3
	140	5.48	7.24	9.05	10.9	12.7	3
	120	5.98	7.93	9.9	11.9	13.9	2.7
	100	6.43	8.54	10.7	12.9	15.1	2.3
	80	6.8	9.05	11.3	13.7	15.9	2