

## FS 120-10 CI

## Single Convolution Air Actuator

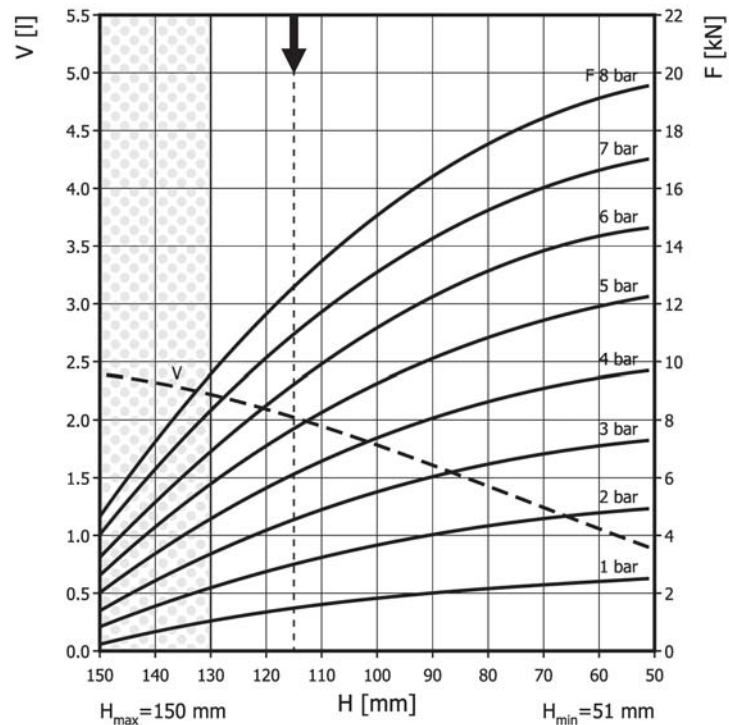

Use in dotted range &gt;130 mm only after consultation with ContiTech

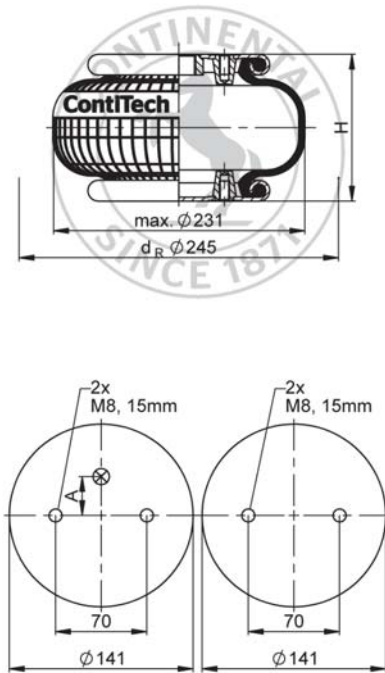

Recommended height for vibration isolation: 115 mm

## Purchase order data

Type	Order No.
Rubber bellows only	62828
with stainless steel crimped plates, G3/4 air inlet 0 mm excentrical	73060

Additional types on request

 Service instructions  
M8: max. 25 Nm  
G3/4: max. 50 Nm

## Technical data

Min. pressure	0 bar
Return force to min height	≤ 200 N
Overall weight	2 kg

## Vibration isolation - dynamic characteristic values

Design height H: recommended 115mm, minimum 100mm

Pressure p [bar]	3	4	5	6	7	8	Vol. V [l]
Force (Load) [kN]	4.8	6.6	8.2	9.9	11.6	13.3	2
Spring rate [N/mm]	132	170	209	242	277	316	
Natural frequency [Hz]	2.7	2.7	2.6	2.6	2.5	2.5	

## Pneumatic application - static characteristic values

Force F [kN]

Pressure p [bar]	3	4	5	6	7	8	Vol. V [l]	
Height H [mm]	120	4.2	5.6	7.2	8.4	10.2	11.7	2.1
	110	4.8	6.6	8.2	9.9	11.6	13.4	2
	100	5.6	7.4	9.2	11.2	13.1	15	1.8
	90	6	8	10.1	12.2	14.2	16.4	1.6
	80	6.5	8.6	10.9	13.2	15.3	17.6	1.4
	70	6.8	9.2	11.4	13.8	16.1	18.4	1.3
	60	7.1	9.4	12	14.4	16.6	19.2	1.1